

Tube Laser Cutting Machine--T Series

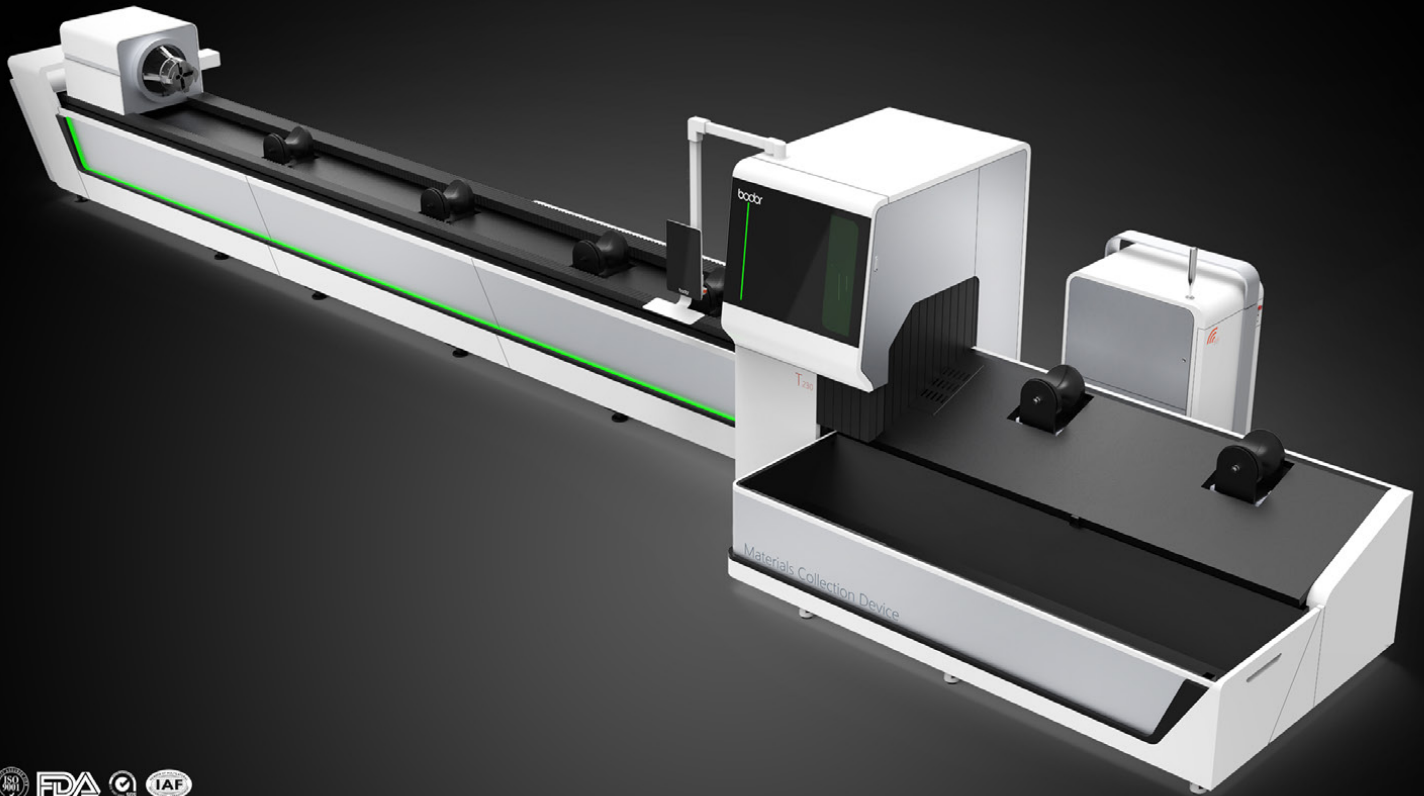

Tube Laser Cutting Machine--T Series

The equipment meets the parts processing requirements of most industries, working accuracy is stable. Selecting the optimal force and supporting structure, the overall mechanical property of equipment is perfect. Adopting cutting-edge optical concept to improve cutting performance. High speed cutting, auxiliary loading and unloading and efficient production reduce labor costs. At present, laser cutting machines have been widely used in electronics, electrical, mechanical hardware, new energy lithium, packaging, solar, LED, automotive and other industries.

Product parameters

Model	T230
Working Area	6500mm
Laser Output Power	4000w/3000w/2000w/1500w/1000w
X/Y-axis positioning accuracy	0.05mm
X/Y-axis repositioning accuracy	0.03mm
X-axis max.moving speed	100m/min
Y-axis max.moving speed	100m/min



BIGGER THAN BIGGER

The diameter is increased by 30%,The weight is increased by 100%,Suitable for various tubes cutting

Tube Laser Cutting Machine T Series

Large size, heavy weight. The maximum cutting area of T series: round pipe is $\varnothing 20 - \varnothing 230$ mm; Square tube is $20 \times 20 - \square 160 \times 160$ mm; Maximum material length is 6500mm; The maximum material weight is 200 kg 30 kg / m. Suitable for more sizes pipes and heavy weight pipes, so T series has a wider application scope.

The first one to use UI design in the world which lets display respond to processing table.



Tube Laser Cutting Machine--T Series

The first one to use UI design in the world which lets display respond to processing table, making processing more intuitive. 1920*1080 high-definition capacitive 10 points touch screen. Elegant curves precisely fit machine body. Strong waterproof breathable system creates the best space, making operation more convenient. Diamond cutting process and HD plasma tempered glass make screen more exquisite and comfortable to use. More enjoyable work methods and cheerful mood can improve work efficiency.

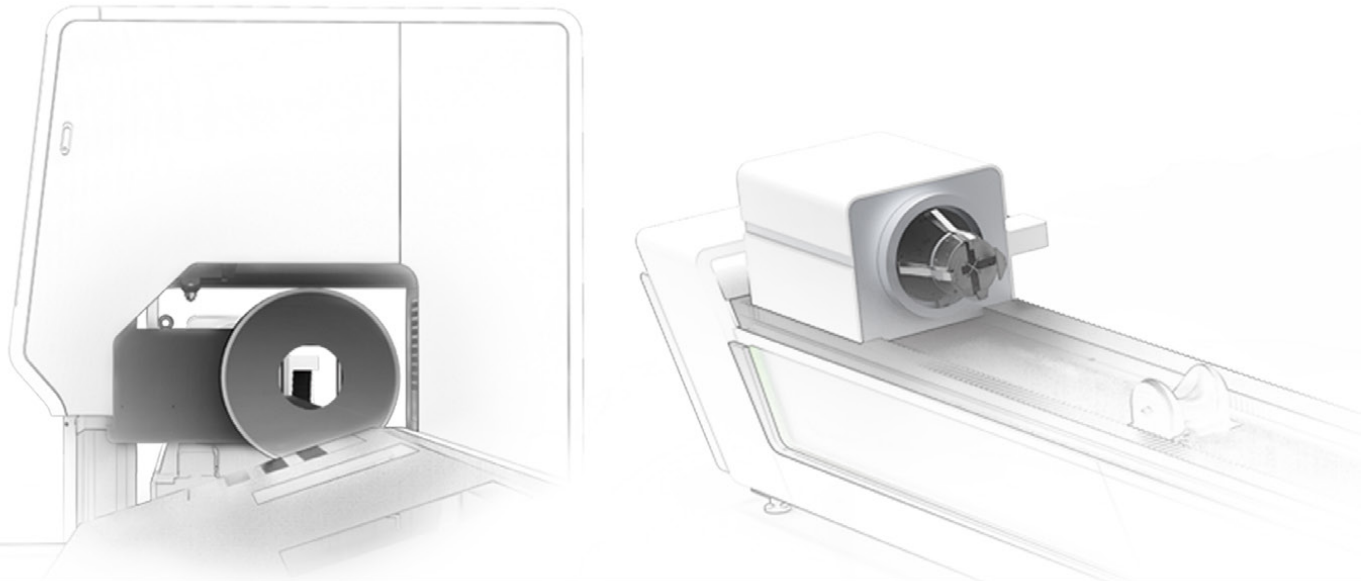

Fully automatic electric chuck

Automatic electric chuck, claw DC motor drive, clamping motor current is sensitive, adjustable and stable, clamping range is wider and clamping force is larger. Non - destructive pipe clamping, fast automatic centering and clamping pipe, performance is more stable. The chuck size is smaller, rotation inertia is low, and dynamic performance is strong. Self-centering electric chuck, gear transmission mode, higher transmission efficiency, long working life and high work reliability.



Bodor Pro-2.0

Four - sided searching, Precision upgrading as low pressure alarm function

Bodor Pro-2.0 Four - sided searching, Precision upgrading

Using a new graphic rendering and presentation, pipe parts can realize dual display as flat and three-dimensional. Plane retouching is simple and quick, three-dimensional can synchronous display. The new four-sided edges searching, optimized edges searching mode and algorithm bring us higher cutting accuracy and accuracy stability.

Tube Laser Cutting Machine--T Series

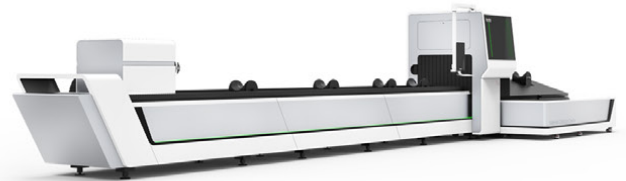
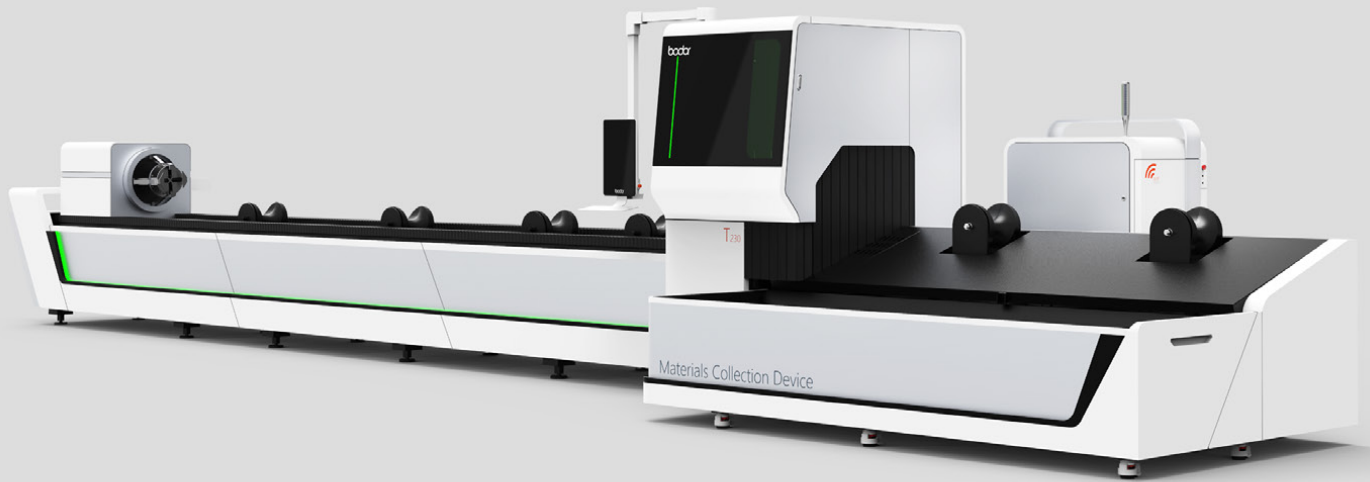

Appearance design

Aesthetics was introduced to industrial ID, perfect combination of technology and aesthetics.

AVAILABLE OPTIONS

Full automatic loading and unloading device

Loading:

After the whole bundle pipes were put on the feeding device, these pipes can be intelligently divided, loaded and connected seamlessly with the pipe cutter to ensure that only one pipe is transported to the delivery arm at a time.

Unloading:

Finished material is automatically unloaded to the parts silo, double rollers auxiliary support long parts; materials can be automatic prepared during processing time, shorten the feeding time.

Automatic unloading, parts and scraps are automatically separated, reducing sorting, saving labor, improving machine production efficiency.

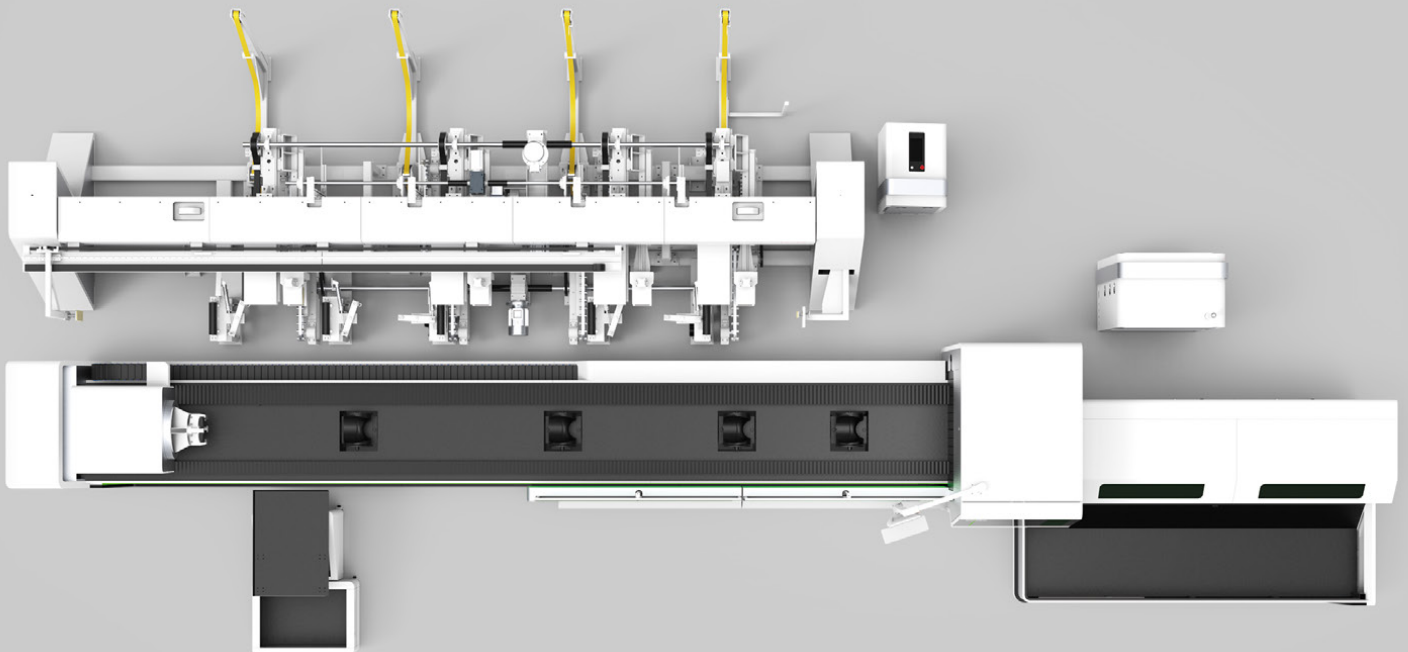

FUNCTIONS

The heavy bed makes the equipment more stable in working, the light crossbeam makes it work faster; perfect industrial design is more in line with man-machine engineering; high quality electrical software control system gives equipment higher cutting precision. The machine owns more comfortable operation, more stable performance, more durable quality, higher cutting efficiency and wider application scope.

Auxiliary feeding mechanism

The promotion and demotion of subsidiary roller table reduces friction force between parts and working table, making loading and unloading more convenient.

Intelligent travel protection

Automatically monitor operation range of crossbeam and cutting parts, keeping operation within machining range. Double guarantees of fixed limitation greatly improve equipment and personal safety, minimizing the using risks.

Automatic lubrication system

Automatic lubrication system provides timing and ration lubricating oil for equipment to ensure its normal and high speed operation, and owns functions of abnormal alarm and liquid level alarm. The system greatly enhances cutting accuracy and effectively extends service life of transmission mechanism.

WIFI remote intelligent assistance

Global real-time feedback ; Providing real-time fault analysis and troubleshooting.

A new generation of safety following module

Laser head keeping distance with work piece in cutting process can reduce collision risks. It will stop cutting when colliding plate. The safety following module reduces accident rate and improves cutting performance.

Intelligent alarm system

The system will start full abnormal alarm and push it to the interface through control center when equipment is abnormal.

Finding equipment abnormal in advance and reducing hidden dangers can multiply improve the equipment troubleshooting efficiency.

Auxiliary gas low pressure alarm function

Providing real-time pressure detection, pushing abnormal information when pressure value is lower than optimal cutting effect and precision. Ensure the cutting performance, accuracy and timeliness of gas replacement.

ADVANTAGES OF LASER CUTTING MACHINE

- 1, High speed, high efficiency and high performance
- 2, High precision, low cost and simple operation
- 3, Extensive processing materials, advanced processing technology and strong flexibility
- 4, Energy-saving and environmental protection, simple maintenance and low operating cost
- 5, High cost performance and standard after-service
- 6, Independently-developed software, simple operation, safety and stable performance
- 7, Reasonable framework, leading technology, superior performance, high speed operation and perfect functions
- 8, Reasonable structure, easy operation, laser source runs stable with low maintenance cost

The advantages of laser cutting compared with traditional cutting methods

1. High precision: Focusing accuracy is 0.05mm, repetition focusing accuracy is 0.02 mm
2. Narrow kerf: The laser beam is focused into a small spot, making the focus reach high power density, the material is quickly heated up to the gasification then evaporates to form holes. With the relative linear movement of the light beam to the material, the hole is continuously formed narrow gaps. Kerf width of the incision is usually 0.10 ~ 0.20mm.
3. Smooth section: Cutting surface without burrs, roughness of incision surface is generally controlled within Ra12.5.
4. Good cutting quality: Non contact cutting, cutting edge is less affected by heat, basically no thermal deformation of work piece, completely avoid down edge formed by material punching, in general, slit doesn't need secondary processing.
5. No damage to work piece: Laser cutting head won't contact surface of material to ensure no scratches to work piece.

Advantages compared with other cutting methods

1. Wire cutting: High precision, difficult to perforate, low cutting speed. Low investment in equipment. The price range of a device is from tens of thousands to hundreds of thousands or so.
2. Laser cutting: High precision, cutting speed is influenced by plate thickness which is generally within 10 m / min. Not suitable for thick plate (only for 0~25mm plate), high investment in equipment is suitable for large batch processing.
3. Water jet cutting: High precision, low cutting speed. It is not suitable for large batch processing, and equipment investment is high.
4. Plasma cutting: High precision(The verticality of the product is not high), fast speed and consumption. Suitable for large batch processing, and equipment investment belongs to medium level.
5. Flame (oxygen) cutting: Accuracy(thermal deformation), low speed, suitable for large batch processing. Equipment investment is small and operation cost is cheap.
6. Punch: Difficult for processing various small-batch materials, suitable for few large batch processing. It is difficult to cut the thick plate. Equipment investment belongs to medium level.
7. Plate shearing machine: Not suitable for curvilinear cutting, straight line cutting is OK, difficult for thick plate cutting.

T230 • FLOOR PLAN

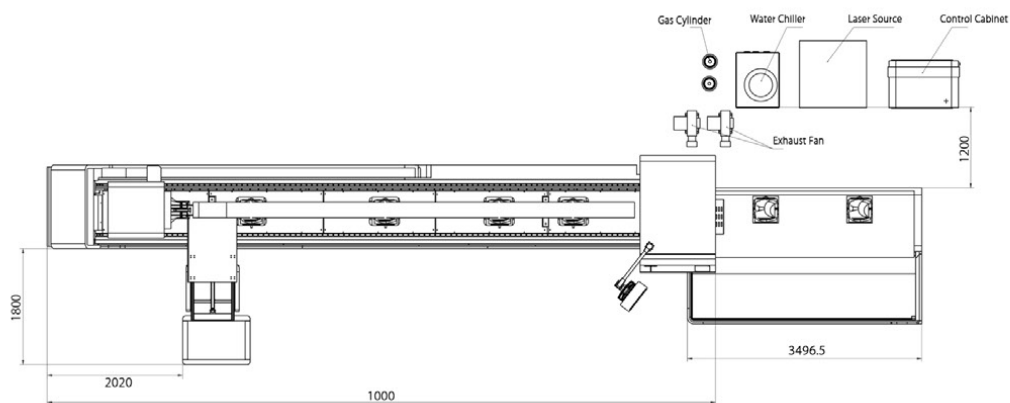
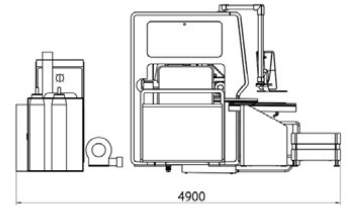
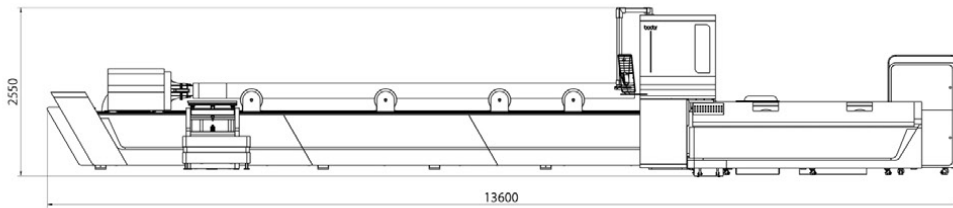

Attention!

Obstacles should be stayed at least 1 meter away from the whole machine;

Machine should be far away from the hypocenter(origin of shocks);

The floor flatness of less than 5mm;

Input voltage floating within + -5%.

Fiber Laser Cutting Process Parameters

		500W	1000W	1500W	2000W	YLR-2000W	3000W	4000W	6000W	8000W	10000W	12000W	15000W
Material	Thickness	speed m/min	speed m/min	speed m/min	speed m/min	speed m/min	speed m/min	speed m/min	speed m/min	speed m/min	speed m/min	speed m/min	speed m/min
Carbon steel (Q235A)	1	7.0-9.0	8.0-10	15-26	24-30	24-32	30-40	33-43					
	2	3.0-4.5	4.0-6.5	4.5-6.5	4.7-6.5	4.7-6.5	4.8-7.5	15-25					
	3	1.8-3.0	2.4-3.0	2.6-4.0	3.0-4.8	3.0-4.8	3.3-5.0	7.0-12					
	4	1.3-1.5	2.0-2.4	2.5-3.0	2.8-3.5	2.8-3.5	3.0-4.2	3.0-4.0					
	5	0.9-1.1	1.5-2.0	2.0-2.5	2.2-3.0	2.2-3.0	2.6-3.5	2.7-3.6					
	6	0.6-0.9	1.4-1.6	1.6-2.2	1.8-2.6	1.8-2.6	2.3-3.2	2.5-3.4					
	8	0.3-0.7	0.8-1.2	1.0-1.4	1.2-1.8	1.2-1.8	1.8-2.6	2.0-3.0					
	10		0.6-1.0	0.8-1.1	1.1-1.3	1.1-1.3	1.2-2.0	1.5-2.4					
	12		0.5-0.8	0.7-1.0	0.9-1.2	0.9-1.2	1.0-1.6	1.2-1.8					
	14			0.5-0.7	0.7-0.8	0.8-1.0	0.9-1.4	0.9-1.2					
	16				0.6-0.7	0.6-0.8	0.7-1.0	0.8-1.0					
	18				0.4-0.6	0.5-0.7	0.6-0.8	0.6-0.9					
	20						0.5-0.8	0.5-0.8					
	22						0.3-0.7	0.4-0.8					
25													
30													
Stainless steel (201)	1	8.0-13	18-25	20-27	24-30	24-50	30-35	32-45					
	2	2.4-5.0	5-7.5	8.0-12	9.0-12	9.0-15	13-21	16-28					
	3	0.6-0.8	1.8-2.5	3.0-5.0	4.0-6.5	4.8-7.5	6.0-10	7.0-15					
	4		1.2-1.3	1.5-2.4	3.0-4.2	3.2-4.5	4.0-6.0	5.0-8.0					
	5		0.6-0.7	0.7-1.3	1.8-2.5	2.0-2.8	3.0-5.0	3.5-5.0					
	6			0.7-1.0	1.2-1.8	1.2-2.0	2.0-4.0	2.5-4.5					
	8				0.7-1.0	0.7-1.0	1.5-2.0	1.2-2.0					
	10						0.6-0.8	0.8-1.2					
	12						0.4-0.6	0.5-0.8					
	14							0.4-0.6					
	20												
	25												
30													
40													
50													
Aluminum	1	4.0-5.5	6.0-10	10-20	15-25	20-30	25-38	35-45					
	2	0.7-1.2	2.8-3.6	5.0-7.0	7-10	10-15	10-18	13-24					
	3		0.7-1.5	2.0-4.0	4.0-6.0	5.0-7.0	6.5-8.0	7.0-13					
	4			1.0-1.5	2.0-3.0	3.5-5.0	3.5-5.0	4.0-5.5					
	5			0.7-1.0	1.2-1.8	1.8-2.5	2.5-3.5	3.0-4.5					
	6				0.7-1.0	1.0-1.5	1.5-2.5	2.0-3.5					
	8				0.6-0.8	0.6-0.8	0.7-1.0	0.9-1.6					
	10						0.4-0.7	0.6-1.2					
	12						0.3-0.45	0.4-0.6					
	16							0.3-0.4					
	20												
	25												
	30												
40													
50													
Brass	1	4.0-5.5	6.0-10	8.0-13	10-16	12-18	20-35	25-35					
	2	0.5-0.9	2.8-3.6	3.0-4.5	4.5-7.5	6.0-8.5	6.0-10	8.0-12					
	3		0.5-1.0	1.5-2.5	2.5-4.0	2.5-4.0	4.0-6.0	5.0-8.0					
	4			1.0-1.6	1.5-2.0	1.5-2.0	3.0-5.0	3.2-5.5					
	5			0.5-0.7	0.9-1.2	0.9-1.2	1.5-2.0	2.0-3.0					
	6				0.4-0.7	0.4-0.9	1.0-1.8	1.4-2.0					
	8						0.5-0.7	0.7-1.2					
	10							0.2-0.5					
	12												
	14												
	16												
18													
20													
25													

The cutting parameters are only for oxygen and nitrogen

Above data is only for reference

For more information, please go to the website : www.bodor.com

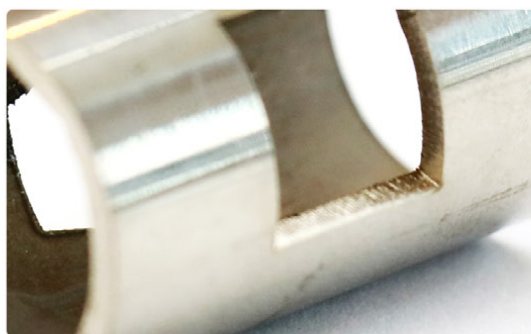
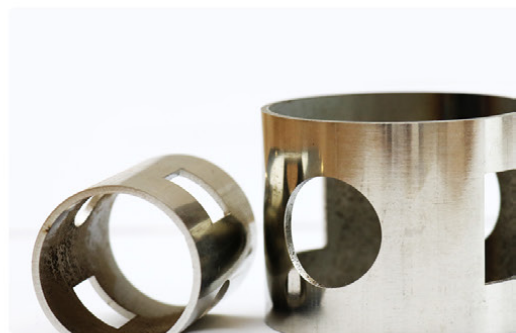

Metal Samples

For more information, please go to the website : www.bodor.com



OFFICE

For more information, please go to the website : www.bodor.com

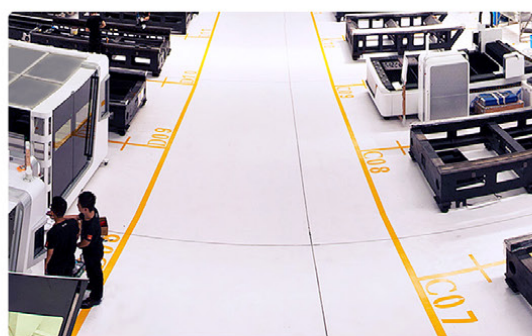
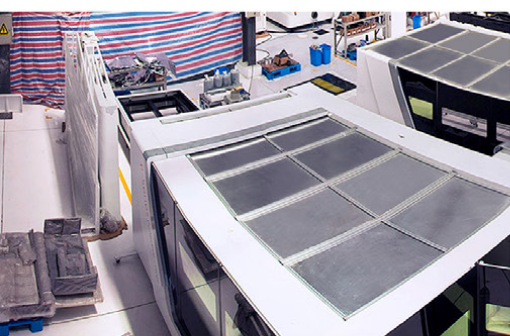

WORKSHOP

For more information, please go to the website : www.bodor.com